

PRODUCT CATALOG

Professional livestock environment equipment manufacturer



BEIJING SHENGSITECHNOLOGY CO., LTD.

Add: 2nd Floor, Baixin Keji Buiding, CAAS,
No.12 South Zhongguancun Street,
Haidian District, Beijing, 100081, China

Tel: +86 10 62132998

Email: intla@sscdrive.com intlb@sscdrive.com

Web: www.sscdrive.com

2023-03

Innovation

Dedication

Reliability

Creditability

WWW.SSCDRIVE.COM

Company profile

Beijing Shengsi Technology Co., Ltd, is a professional manufacturer specialized for gear motor and environment control equipment for livestock industry and dedicated to research, manufacturing and sale of facility agricultural machines and electronic products. Main products include gear motor, electrical winch, climate controller, which are widely used in the field of ventilation, curtain system and hoisting of livestock house, and we also provide different types of agricultural curtain systems.

The company headquarter is located in Beijing, with 3 R&D centers, has modern workshop under cover of 40,000 square meters. Products have been exported to more than 60 countries and regions all around the world, accordingly, a total quality management system with traceability was established.

Contents

01 Gear Motor Series

| | |
|--------------------------------|------|
| 3GG® Gear Motor | P 06 |
| KINGZO® Cable-Winch Gear Motor | P 08 |
| KINGZO® Gear Motor | P 10 |

02 Electric Roll-up Motor Series

| | |
|--------------------------------|------|
| KINGZO® Electric Roll-up Motor | P 16 |
| TOUP® Intel Rolling Motor | P 20 |
| FLC® Guiding Bracket | P 22 |

03 Agricultural Curtain System

| | |
|--------------------------|------|
| Motorized Curtain System | P 26 |
| Manual Curtain System | P 32 |
| PE Woven Fabric | P 35 |

04 Other Products

| | |
|-----------------------------|------|
| Rack and Pinon System | P 38 |
| Roof Ventilator | P 40 |
| VINIPET® Wiggle Wire | P 41 |
| LOCKUP® Wiggle Wire Channel | P 42 |
| Curtain Retainer Band | P 43 |

01 Gear Motor Series

3GG® Gear Motor



3GG® Triple Protection and Self-locking Gear Motor

- 01 The built-in integrated control box reduces the cost of electric control and cable.
- 02 Manual and automatic mode switching can realize installation and debugging by one person.
- 03 Built-in "overload, open-phase, commutation" protection device.

| Model | Voltage | Power | Current | RPM | Torque | Braking distance | Weight |
|-----------------|---------|-------|---------|-----------|---------|------------------|--------|
| G400A-250-1.3 | AC 380V | 250W | 1.1A | 1.3 r/min | 400N·m | ≤10mm | 23Kg |
| G400A-550-2.6 | AC 380V | 550W | 1.5A | 2.6 r/min | 400N·m | ≤10mm | 21Kg |
| G400A-550-2.6 | AC 220V | 550W | 3.2A | 2.6 r/min | 400N·m | ≤10mm | 21Kg |
| G400A-550-5.2 | AC 380V | 550W | 1.9A | 5.2 r/min | 400N·m | ≤10mm | 22Kg |
| G400A-550-5.2 | AC 220V | 550W | 3.6A | 5.2 r/min | 400N·m | ≤10mm | 22Kg |
| G800A-750-2.6 | AC 380V | 750W | 2.0A | 2.6 r/min | 800N·m | ≤10mm | 33Kg |
| G800A-1100-5.2 | AC 380V | 1100W | 3.0A | 5.2 r/min | 800N·m | ≤10mm | 35Kg |
| G1200A-1100-2.6 | AC 380V | 1100W | 2.6A | 2.6 r/min | 1200N·m | ≤10mm | 35Kg |
| G1200A-1500-5.2 | AC 380V | 1500W | 3.5A | 5.2 r/min | 1200N·m | ≤10mm | 37Kg |

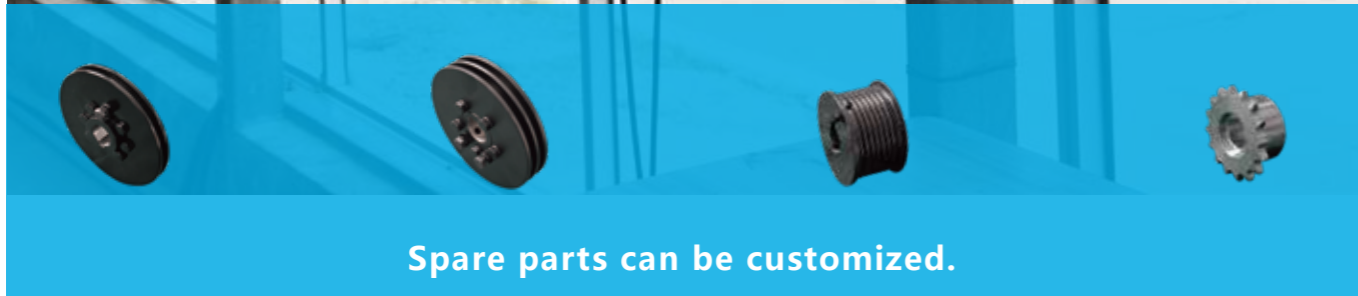

Spare parts can be customized.

- 01 The Built-in Potentiometer makes sure precise position feedback.
- 02 The special mechanical design reduces complaints rate.
- 03 Excellent Self-locking function with braking distance less than 10mm.
- 04 The motor adds "overload, open-phase" protection function.



| Model | Voltage | Power | Current | RPM | Torque | Braking distance | Weight |
|----------------|---------|-------|---------|-----------|---------|------------------|--------|
| G400-250-1.3 | AC 380V | 250W | 1.1A | 1.3 r/min | 400N·m | ≤10mm | 21Kg |
| G400-550-2.6 | AC 380V | 550W | 1.5A | 2.6 r/min | 400N·m | ≤10mm | 20Kg |
| G400-550-5.2 | AC 380V | 550W | 1.9A | 5.2 r/min | 400N·m | ≤10mm | 20Kg |
| G400-550-2.6 | AC 220V | 550W | 3.2A | 2.6 r/min | 400N·m | ≤10mm | 21Kg |
| G400-550-5.2 | AC 220V | 550W | 3.6A | 5.2 r/min | 400N·m | ≤10mm | 22Kg |
| G800-750-2.6 | AC 380V | 750W | 2.0A | 2.6 r/min | 800N·m | ≤10mm | 32Kg |
| G800-1100-5.2 | AC 380V | 1100W | 3.0A | 5.2 r/min | 800N·m | ≤10mm | 34Kg |
| G1200-1100-2.6 | AC 380V | 1100W | 2.6A | 2.6 r/min | 1200N·m | ≤10mm | 34Kg |
| G1200-1500-5.2 | AC 380V | 1500W | 3.5A | 5.2 r/min | 1200N·m | ≤10mm | 36Kg |





KINGZO®

Cable-Winch Gear Motor

- 01 Double limit switch design, with working and safe limit switch can ensure more reliable system operation.
- 02 Built-in “overload, open-phase” protection device.
- 03 Three years warranty.

| Model | Voltage | Power | Current | RPM | Torque | Weight |
|-------------------|---------|-------|---------|----------|--------|--------|
| GMA250-D-600-1.3C | AC380V | 250W | 1.1 A | 1.3r/min | 600N·m | 25Kg |
| GMA550-D-600-2.6C | AC380V | 550W | 1.6 A | 2.6r/min | 600N·m | 26Kg |
| GMA550-D-800-1.3C | AC380V | 550W | 1.4 A | 1.3r/min | 800N·m | 24Kg |
| GMA750-D-800-2.6 | AC 380V | 750W | 2.0A | 2.6r/min | 800N·m | 28Kg |



Applications: Air inlet system, tunnel door system.

KINGZO® Gear Motor



Nest Expel System



Guillotine Ventilation



Tunnel door R&P system

01 Double limit switch design, with working and safe limit switch can ensure more reliable system operation.

02 Built-in "overload, open-phase" protection device.

03 Three years warranty.



| Model | Voltage | Power | Current | RPM | Torque | Weight |
|------------------|---------|-------|---------|----------|--------|--------|
| GMA550-D-400-5.2 | AC 380V | 550W | 1.8A | 5.2r/min | 400N·m | 25Kg |
| GMA550-D-600-2.6 | AC 380V | 550W | 1.6A | 2.6r/min | 600N·m | 26Kg |
| GMA750-D-600-5.2 | AC 380V | 750W | 2.2A | 5.2r/min | 600N·m | 27Kg |
| GMA750-D-800-2.6 | AC 380V | 750W | 2.0A | 2.6r/min | 800N·m | 28Kg |



Spare parts can be customized.



Rack and Pinion Roof Vent system



Curtain Vent system



Feeding line Hoisting System

Kingzo® Gear Motor

Kingzo® Gear Motor (250/200N.m)

Easy Installation, Adjustable by one person, Labor-saving

- 01 Excellent self-locking performance
- 02 With higher dust proof grade of IP65
- 03 Manual release design, in case of power failure, can open or close vent manually in very short time
- 04 Potentiometer is available for precise and intel control
- 05 Compact structure, small size, light weight.
- 06 With 5 meters external cable, convenient to connect the control cabinet



| Model | Voltage | Power | Current | RPM | Torque | Weight | Warranty |
|--------------|---------|-------|---------|----------|--------|--------|----------|
| GMA180-D-200 | AC 220V | 180W | 1.8A | 3.0r/min | 200N·m | 9.0Kg | 3years |
| GMD180-D-200 | DC 24V | 180W | 15.0A | 3.0r/min | 200N·m | 9.2Kg | 3years |
| GMA250-D-250 | AC 220V | 250W | 2.0A | 3.2r/min | 250N·m | 9.0Kg | 3years |
| GMD250-D-250 | DC 24V | 250W | 18.0A | 3.2r/min | 250N·m | 9.0Kg | 3years |



Curtain Ventilation



Rack and Pinion Ventilation

Kingzo® Gear Motor (150/120N.m)

- 01 Effectively prevent the unbalance of gear motor due to the long rolling tube.
- 02 Dual Output shaft, film rolling at both ends.
- 03 High torque, high film rolling capacity, more economical.
- 04 With anti-condensation drainage holes, Protection Grade: IP55 (dustproof and waterproof).
- 05 Providing 5 meters long external electric cable for easy connection to the control box.



| Model | Voltage | Power | Current | RPM | Torque | Weight | Warranty |
|--------------|---------|-------|---------|----------|--------|--------|----------|
| GMA120-D-120 | AC 220V | 120W | 1.0A | 2.7r/min | 120N·m | 6.1Kg | 3years |
| GMD120-D-120 | DC 24V | 120W | 7.5A | 2.7r/min | 120N·m | 6.1Kg | 3years |
| GMA150-D-150 | AC 220V | 150W | 1.4A | 2.8r/min | 150N·m | 6.5Kg | 3years |
| GMD150-D-250 | DC 24V | 150W | 9.3A | 2.8r/min | 150N·m | 6.5Kg | 3years |



Curtain Ventilation



Rack and Pinion Ventilation



02 Electric Roll-up Motor Series



- 01 Connect AC 220V power directly.
- 02 Overloading and miswiring Protection.
- 03 Reinforced output shaft.
- 04 Accurate limit switch and reliable self-locking function.
- 05 IP55 with anti-Condensation function .
- 06 Three years warranty.

KINGZO®

Electric Roll-up Motor 220V AC

| Model | Voltage | Power | Current | RPM | Torque | Weight |
|-------------|---------|-------|---------|----------|--------|--------|
| GMA60-S | AC220V | 60W | ≤0.5A | 2.8r/min | 60N-m | 3.7Kg |
| GMA100-S | AC220V | 100W | ≤0.8A | 2.8r/min | 100N-m | 3.9Kg |
| GMA120-S-A1 | AC220V | 120W | ≤0.9A | 2.5r/min | 120N-m | 4.5Kg |
| GMA300-S | AC220V | 300W | ≤3.0A | 3.5r/min | 300N-m | 8.0Kg |



Roll over Curtain Ventilation



Guillotine Ventilation



Film Rolling



24V DC Motor For Curtain System

KINGZO® Electric Roll-up Motor 24V DC

| Model | Voltage | Power | Current | RPM | Torque | Weight |
|-------------|---------|-------|---------|----------|--------|--------|
| GMD60-S | DC24V | 60W | ≤3.7A | 2.8r/min | 60N·m | 3.7Kg |
| GMD100-S | DC24V | 100W | ≤6.2A | 2.8r/min | 100N·m | 3.7Kg |
| GMD100-S-A1 | DC24V | 100W | ≤6.2A | 2.8r/min | 100N·m | 4.1Kg |
| GMD180-S | DC24V | 180W | ≤11.0A | 3.3r/min | 180N·m | 7.9Kg |
| GMD300-S | DC24V | 300W | ≤20.0A | 3.5r/min | 300N·m | 8.0Kg |

- 01 Low noise, big torque.
- 02 Reinforced output shaft.
- 03 Accurate limit switch and reliable self-locking function.
- 04 Double limit switch design.
- 05 IP55 with anti-Condensation function.
- 06 Three years warranty.



Rack and Pinion Roof Ventilation



Toup® Intel Rolling motor 150N.m Roll up curtain (120m length)

- 01 Patented tension balance mechanism
- 02 Preventing torsion or torn of the curtain fabric, preventing motor dropping from curtain end
- 03 Extending roll up curtain length up to 50% with more straight roll up tube
- 04 Labor cost saving up to 50%, due to self adjustment of motor drive and roll up tube



Toup® Intel Rolling motor

Toup® Intel Rolling motor is drive gear with tension balance mechanism, it is widely used for vertical roll up curtain system, can help farmers enhance profit, reduce heating cost in livestock shed by providing insulated curtain system.

| Model | Voltage | Power | Torque | Current | RPM | Single/ Dual Shaft | Rolling Tube Dia | Weight |
|------------------|---------|-------|---------|---------|----------|--------------------|------------------|--------|
| GMA150-S-AL45II | AC220V | 150W | 150N-m | 1.7A | 2.8r/min | Single | 50mm | 7.3Kg |
| GMA300-S-AL45 | AC220V | 300W | 300N-m | 3.3A | 3.3r/min | Single | 50mm | 13.3Kg |
| GMA250-D-AL45 | AC220V | 250W | 250N-m | 2.6A | 3.5r/min | Dual | 50mm | 10.7Kg |
| GMA550-D-600-1.3 | AC380V | 550W | 600N-m | 1.6A | 1.3r/min | Dual | 50 or 60mm | 40.0Kg |
| GMA550-D-1200-AL | AC380V | 550W | 1200N-m | 2.1A | 1.3r/min | Dual | 50 or 60mm | 50.0Kg |

Note: Three years warranty.



Roll up of insulated curtain

CRP150-F

Installation Sketch

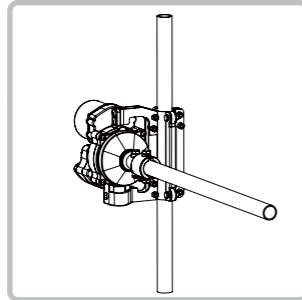
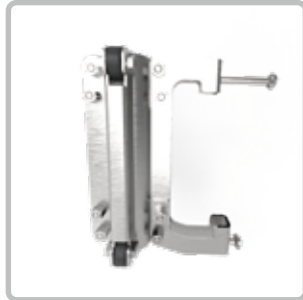

| Model | Applied Motor | Climbing tube Dia. | Unit |
|---------------|------------------------|--------------------|------|
| CRP150-F-DN28 | For 60W/90W/120W/150W | Φ27.5 | pc |
| CRP150-F-DN34 | Electric Roll-up Motor | Φ33.5 | pc |

CRP300-F

Installation Sketch

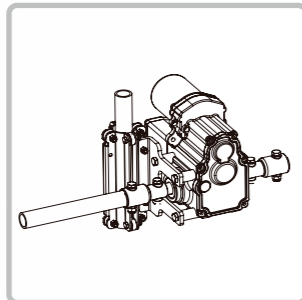

| Model | Applied Motor | Unit |
|---------------|---|------|
| CRP300-F-D34B | For 120W/150W/180W/250W/300W Gear motor | pc |

PSQ-10

Installation Sketch

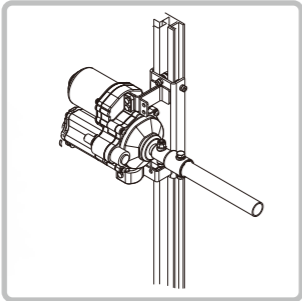

| Model | Applied Motor | Unit |
|--------|---|------|
| PSQ-10 | For 60/100/120W single shaft motor to climb the Aluminum Rail | pc |

FLC-XPSJ

Installation Sketch

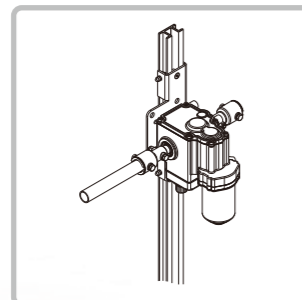

| Model | Applied Motor | Unit |
|-------------|--|------|
| FLC-XPSJ-00 | For 120/150/180/250W dual shaft motor to climb the Aluminum Rail | pc |



FLC® Guiding Bracket

03 Curtain System



Motorized Curtain Roll Up System

- 01 Fast installation, free maintenance.
- 02 Three years warranty for the motor drive.
- 03 Motor available of 220V/110V AC or 24 DC.
- 04 UV stabilized Woven PE Curtain, 5 years warranty.
- 05 Systems in Roll-up, drop down, center drive, end drive etc.

Electric Roll-up Lectotype (Roll-up Type)

| Model | Voltage | Power | Current | RPM | Torque | Rolling Length | Rolling Tube Dia(mm) | Climbing Tube Dia(mm) | Weight |
|-------------|---------|-------|---------|-----------|--------|----------------|----------------------|-----------------------|--------|
| GMA60-S | AC 220V | 60W | ≤0.5A | 2.8 r/min | 60N·m | ≤20m | 50mm | 27.5<D<33.5 | 3.7kg |
| GMA100-S | AC 220V | 100W | ≤0.8A | 2.8 r/min | 100N·m | ≤30m | 50mm | 27.5<D<33.5 | 3.9kg |
| GMA120-S-A1 | AC 220V | 120W | ≤0.9A | 2.5 r/min | 120N·m | ≤35m | 50mm | 27.5<D<33.5 | 4.5kg |
| GMA150-D | AC 220V | 150W | ≤1.4A | 2.8 r/min | 150N·m | ≤40m | 50mm | 27.5<D<33.5 | 6.5kg |
| GMA180-D | AC 220V | 180W | ≤1.8A | 3.2 r/min | 200N·m | ≤60m | 50mm | 27.5<D<33.5 | 9.0kg |
| GMA250-D | AC 220V | 250W | ≤1.8A | 3.5 r/min | 250N·m | ≤70m | 50mm | 27.5<D<33.5 | 9.0kg |



Roll over Curtain Ventilation



Roll up Curtain Ventilation



Top down Curtain Ventilation

Material Configuration (Roll-up Type)

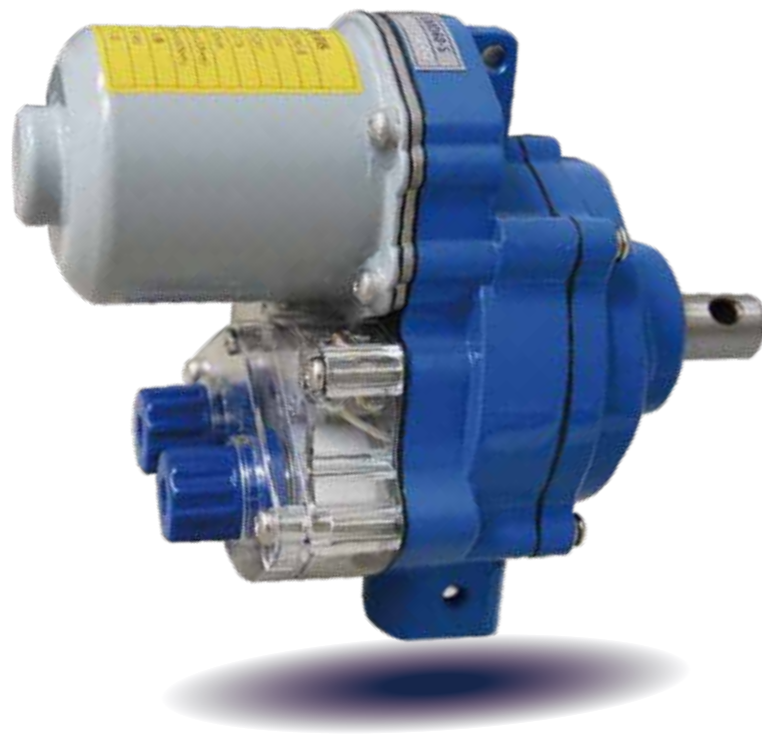

KINGZO®
Electric Roll-up Motor 24V DC

| | | |
|-------------------------------------|-------------------------------------|------------------------|
| Controller | Power Supply | Keder Bar |
| | | |
| Aluminum Single groove rolling tube | Aluminum double groove rolling tube | Adaptor |
| | | |
| Aluminum guiding rail | Guiding tube | Tapping Screw |
| | | |
| Creeper | PE Fabric | Electric Roll-up Motor |
| | | |

Material Configuration (Roll over Type)

| | | |
|---|---|---|
| Bearing Plate | Reversal Pulley | Switch Box |
|  |  |  |
| Adaptor | PE Fabric | Keder Bar |
|  |  |  |
| Aluminum Single groove rolling tube | Electric Winch(AC) | Electric Winch(DC) |
|  |  |  |



**KINGZO® Planetary motor gear box
with intergrated cable drum**

Manual Roll up Curtain System

Material Configuration



Keder Bar



Adaptor



PE Fabric



Aluminum Single groove rolling tube



Aluminum double groove rolling tube



Guiding tube



Expansion Bolt



Curtain Retainer Band



Manual Winch



FLC® Manual Winch



PE Woven Fabric



Color: White (semi-transparent)

Weight: 200g/sqm, 380g/sqm (width: 2.45m/3m)

Standard width: 1.7m/2.1m/2.45m/2.7m/3m (300g/sqm)

Materials: 100% new PE + double side laminating + UV

Life: 5-10 years

Application: Curtain system of dairy, poultry and swine house.

| Specification(300g/sqm) | | | | | | |
|-------------------------|-------|-------|-----------------|----------------|----------------------|-----------------------|
| Item | MESH | UV | Radial strength | Zonal strength | Radial tear strength | Filling tear strength |
| Unit | | % | N | N | N | N |
| Test Data | 16*14 | 5%+5% | 1500 | 1500 | 250 | 250 |

04 Other Products





1" Powder Metallurgy Pinion with Bronze Insert



1" Stainless Steel Pinion with Bronze Insert



1" Powder Metallurgy Pinion with Nylon Insert



| Sash Bracket | Model | Specs |
|--------------|--------|------------------------------------|
| | XMZ-LZ | Aluminum, including pin, pin shaft |

| Ventilation Pinion | Model | Specs | Height | Unit |
|--------------------|--------------|--|--------|------|
| | CLKC—ATF1—30 | 1" Powder Metallurgy Pinion with Bronze Insert | 30mm | pc |
| | CLKC—ATB1—30 | 1" Stainless Steel Pinion with Bronze Insert | 30mm | pc |
| | CLKC—ANF1—30 | 1" Powder Metallurgy Pinion with Nylon Insert | 30mm | pc |



| 411mm rack | Length | Thickness | Height | Remark |
|------------|--------|-----------|--------|---------------|
| | 411mm | 2mm | 22mm | Caging System |



| Curved Rack | Model | Length | Thickness | Height | Unit |
|-------------|----------------|--------|-----------|--------|------|
| | CTKH-2.0301050 | 1050mm | 2.0mm | 30mm | pc |
| | CTKH-2.0301250 | 1250mm | 2.0mm | 30mm | pc |
| | CTKH-2.5301050 | 1050mm | 2.5mm | 30mm | pc |
| | CTKH-3.0301250 | 1250mm | 3.0mm | 30mm | pc |

Note: customized length is available.



| Rack Arm | Model | Length | Thickness | Height | Unit |
|----------|----------------|--------|-----------|--------|------|
| | CTKZ-2.0301050 | 1050mm | 2.0mm | 30mm | pc |
| | CTKZ-2.0301250 | 1250mm | 2.0mm | 30mm | pc |
| | CTKZ-2.5301050 | 1050mm | 2.5mm | 30mm | pc |
| | CTKZ-2.5301250 | 1250mm | 2.5mm | 30mm | pc |
| | CTKZ-3.0301050 | 1050mm | 3.0mm | 30mm | pc |
| | CTKZ-3.0301250 | 1250mm | 3.0mm | 30mm | pc |

Note: customized length is available.



Nest Expel System



Tunnel Door R&P System

Rack and Pinion system



Roof Ventilator



- 01 Excellent performance of dehumidification and cooling.
- 02 Rainproof design.
- 03 UV stabilization extend life span.
- 04 Easy installation.
- 05 Expel the ammonia waste air in the house.
- 06 Three years warranty.

| Model | Air Flow | Blade diameter | RPM | Frequency | Voltage | Current | Power | Weight | Warranty |
|---------------|-----------|----------------|-----------|-----------|---------|---------|-------|--------|----------|
| XT-PQD/DD-400 | 4600m³/h | 390mm | 1390r/min | 50Hz | 220V | 0.9A | 200W | 7.5kg | 3 years |
| XT-PQD/550DD | 10000m³/h | 550mm | 1320r/min | 50Hz | 220V | 2.8A | 550W | 17.0kg | 3 years |

VINIPET® Wiggle Wire

- 01 Four blue anti-fake strips.
- 02 Two thick ends, easy to install with high efficiency.
- 03 Coated with engineering plastic powder, better anti-aging character.
- 04 Withstand wind up to 12 grade.
- 05 Six years warranty.

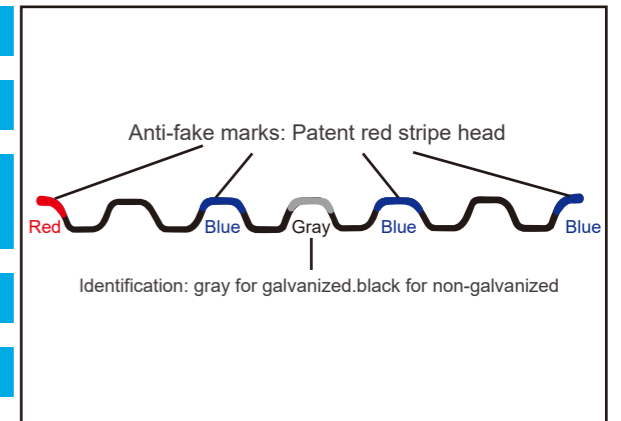

| Model | Specification | Color | Guarantee |
|-------|---------------|-------|-----------|
| B6-20 | Φ2.0mm | Black | 6 years |



LOCKUP® Wiggle Wire Channel



LOCKUP® Galvanized
Wiggle Wire Channel



LOCKUP® Swedged
Galvanized Wiggle Wire Channel

| Model | Specification | Width(mm) | Height(mm) | Thickness(mm) | Zinc Coating | Length(m/pc) |
|-------------|---------------|-----------|------------|---------------|----------------------|--------------|
| KF-3B (120) | Standard | 30mm | 11mm | 0.7mm | ≥120g/m ² | 4m/6m |
| KF-3B (275) | Standard | 30mm | 11mm | 0.7mm | ≥275g/m ² | 4m/6m |
| KF-4 | Standard | 31.5mm | 13.5mm | 0.9mm | ≥275g/m ² | 4m/6m |
| KF-3BS | Swedged | 30mm | 11mm | 0.7mm | ≥120g/m ² | 4m/6m |
| KF-3BS | Swedged | 30mm | 11mm | 0.7mm | ≥275g/m ² | 4m/6m |
| KF-4S | Swedged | 31.5mm | 13.5mm | 0.9mm | ≥275g/m ² | 4m/6m |

Note: customized length is available.

Two options for Wiggle Wire Channel Connecting

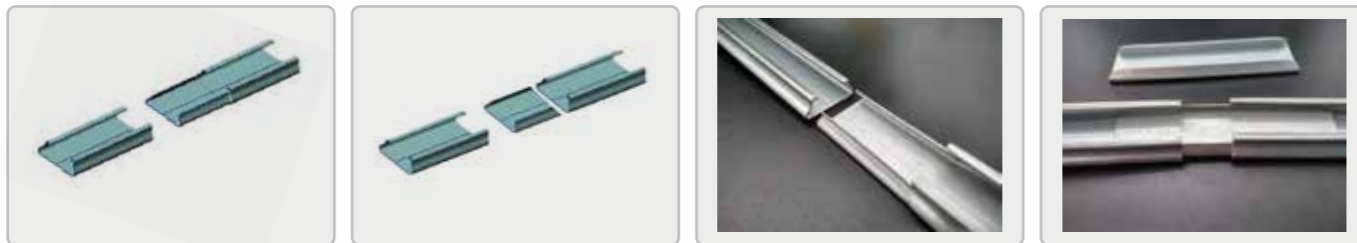

Curtain Retainer Band



01 High tensile strength.

02 Small coefficient of expansion and contraction.

03 UV stablization.

